

# RINATO SPA™

## INSTALLATION INSTRUCTIONS



**EUROPEAN TOUCH®**  
*The World's Finest Pedicure Spas*

## European Touch - Limited Warranty

EUROPEAN TOUCH manufactures the Rinato® Whirlpool Pedicure Spa with the highest standards for quality materials and workmanship. EUROPEAN TOUCH expressly warrants its products as follows:

To the original owner (herein called "owner") of the Rinato Whirlpool Pedicure Spa (herein called "pedicure spa"): EUROPEAN TOUCH may repair or replace, at its option, any pedicure spa found to be defective in material or workmanship upon inspection by an authorized representative of EUROPEAN TOUCH. This limited warranty covers the following components for the following time periods:

- All components: 12 months from date of shipment from manufacturer's facility.

The exchange of a pedicure spa is limited to supplying a replacement pedicure spa of comparable style and size. EUROPEAN TOUCH may, at its own discretion, use refurbished parts or pedicure spas for replacement purposes. The owner must pay all labor and shipping charges necessary to repair or replace the product. **NO CONSEQUENTIAL, INCIDENTAL, CONTINGENT, COMPENSATORY, INDIRECT, SPECIAL, OR OTHER DAMAGES WILL BE ALLOWED.** This limited warranty is null and void if the pedicure spa is removed from its place of initial installation, or is not installed in accordance with the specifications of European Touch or federal, state or local codes and ordinances. Furthermore, this warranty does not apply if the pedicure spa has been subject to misapplication, improper installation or maintenance, negligence, improper cleaning or other circumstances beyond EUROPEAN TOUCH's control.

### NOT COVERED:

1. Damage to pump parts and/or motor parts due to obstruction in plumbing lines, etc.
2. Staining, fading or discoloration of plastic surfaces due to exposure and/or the use of harmful cleaning agents or chemicals.
3. Staining, fading or discoloration caused by improper or poor water additives not related to maintenance of water are not covered by this warranty.
4. Malfunctions or damage caused by improper installation; including, but not limited to, failure to meet local and state plumbing, electrical, and building codes.
5. Staining, fading or discoloration of the vinyl seat, armrests, or footrests.
6. Damage resulting from standing in the basin.
7. Freight damage, misuse, modification, neglect, accident, natural disaster, and abuse.
8. Unauthorized repairs.
9. Damage while in possession of any party other than European Touch.

Should service be required due to a defect or malfunction during the warranty period, please contact:

EUROPEAN TOUCH  
Technical Support  
Toll-Free: 1-800-626-6912  
Phone: 1-414-357-7016  
Fax: 1-414-357-6360  
[service@europeantouch.com](mailto:service@europeantouch.com)  
<http://www.europeantouch.com>

The owner agrees by using this pedicure spa (a) that the obligation of EUROPEAN TOUCH shall not extend to indirect or contingent damages, or injury, which may result from such use and (b) that the obligations of EUROPEAN TOUCH are limited to those set forth herein. This limited warranty is the exclusive remedy and is in lieu of all other warranties express or limited, including, but not limited to, any implied warranty of merchantability or fitness for a particular purpose. No dealer or other person has any authority to bind EUROPEAN TOUCH to changes or additions to this warranty or its products. Accordingly, EUROPEAN TOUCH is not responsible for any such warranties or representations.

### OTHER PROVISIONS:

- This warranty is limited to the original owner/end-user and is not transferable.
- European Touch shall not be liable for any other obligations or liabilities, including, but not limited to, obligations or liabilities arising out of breach of contract or warranty, negligence, or other tort or any theory of strict liability with respect to the pedicure spa or the acts or omissions of European Touch.
- Any assistance European Touch provides to the original owner outside the terms, limitations or exclusions of this limited warranty will not constitute a waiver of search terms, limitations or exclusions, nor will such assistance extend or revive the warranty.



# EUROPEAN TOUCH™

## Table of Contents

<b>European Touch - Limited Warranty .....</b>	<b>2</b>
<b>Installation Specifications Summary .....</b>	<b>4</b>
<b>Location and Support.....</b>	<b>4</b>
<b>Important Installation and Utility Information .....</b>	<b>5</b>
<b>Attaching the Seat Back and Seat Bottom Cushion .....</b>	<b>7</b>
Seat Back Attachment.....	7
Seat Movement Attachment .....	7
Seat Bottom Attachment .....	8
<b>Installing and Removing the Panel .....</b>	<b>9</b>
<b>Installing the floor Mounting Brackets .....</b>	<b>10</b>
<b>GROUNDING INSTRUCTIONS .....</b>	<b>11</b>
DANGER.....	11

# Installation Specifications Summary

*Note: Failure to comply with federal, state or local codes and ordinances will result in warranty being null and void.*

This pedicure spa installation must comply with all applicable plumbing and electrical codes. A licensed plumber and licensed electrician must make the utility connections to this spa.

**WARNING: Front plate and side covers MUST be removed prior to moving and installing the Rinato Spa.**

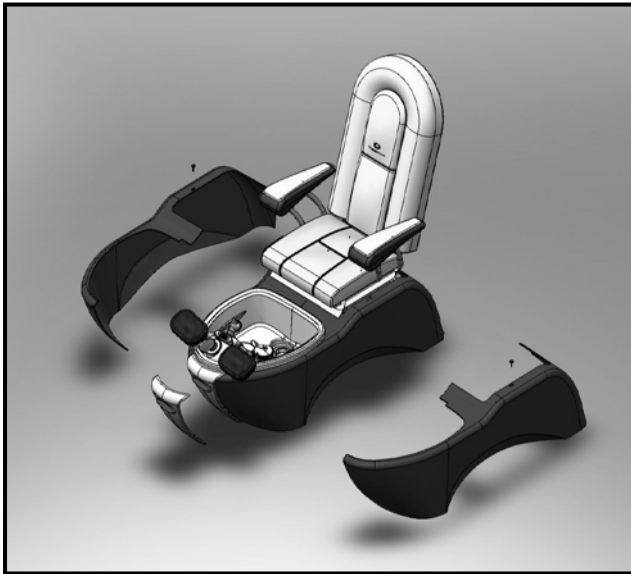

Spa shipping configuration removal



Appearance when set into place

## Location and Support

Select a level floor location for installation. The floor structure beneath the pedicure spa must be capable of supporting the occupied unit. For the seat back to fully recline, the spa base must be mounted at least 17 inches from the wall as shown below:

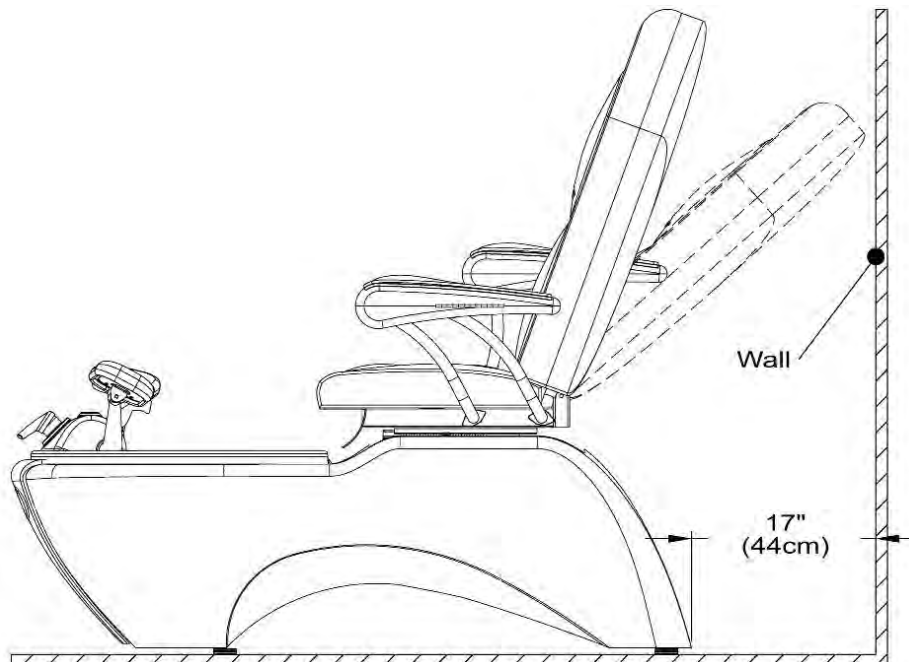

## Important Installation and Utility Information

### Electrical Service:

- 110V:** 110V, 60 Hz, 2.75 Amp GFCI protected grounded circuit must be used to supply power to the pedicure spa. (220V if ordered in 220V configuration)
- 220V:** 220V, 50/60 Hz, 2.75 Amp GFCI protected grounded circuit must be used to supply power to the pedicure spa.

### Water Supply:

- All plumbing connections must conform to local codes.
- Water pressure must be 30 to 80 PSI for the sprayer to operate correctly.
- Maximum operating water temperature should not exceed 105° F (41° C) and the maximum supply water temperature should not exceed 150° F (65° C). *(In Massachusetts, the maximum supply water temperature should not exceed 130° F (54° C)).* Adjust the hot water heater accordingly.
- For hot and cold water supply fittings and power drain fittings location, see figure 1 below.
- Carefully connect the incoming water supply lines to the appropriate fittings located on the back of the pedicure spa. Shut-off valves are recommended.

The pedicure spa drain must meet local plumbing codes. **(Pedicure Spa must be installed by a licensed plumber)** see pages six and eleven.

*\*\*Note: See local and state codes as to what type of drain connection is required to be made.*

Hot & Cold supply fittings contain Neoperl® DW15GF check valves.

The drain line must be a minimum of 3/4" inside diameter from Spa to wall connection for basin to drain properly.

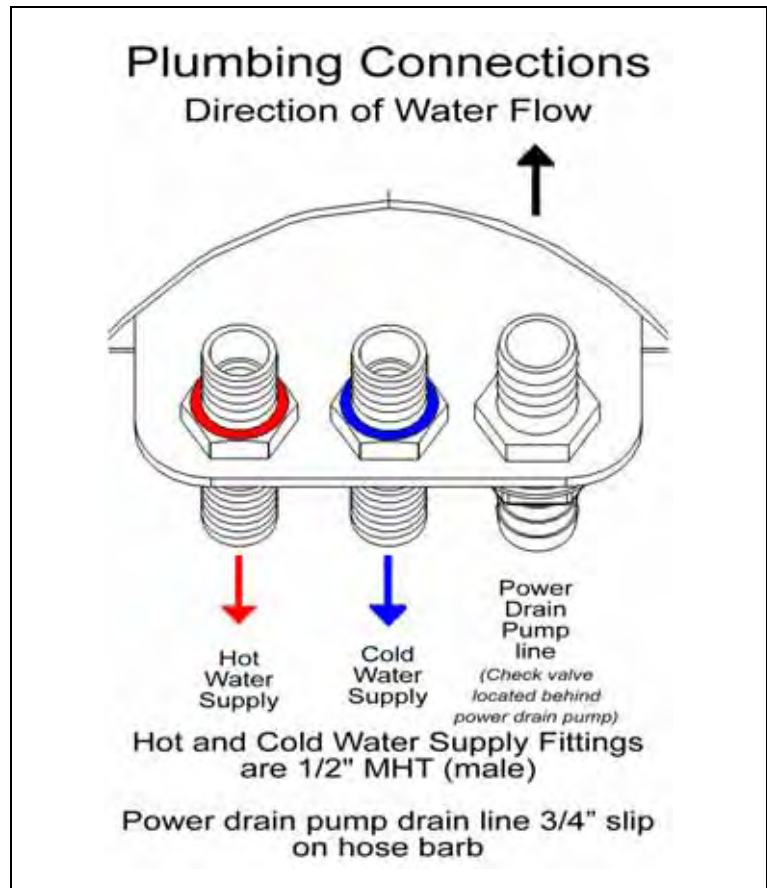

Back of Pedicure Spa

**Note:** *Not using the supplied bulkhead fittings will result in NO backflow protection. Check your Local & State plumbing codes for additional backflow requirements. Any additional requirements are the responsibility of the owner of the unit.*

**Backflow Protection Devices for Faucets with Side Spray:** Check valves comply with ANSI/ASME A112.18.3M, A112.18.1M, and CSA B12

**NOTE:** Cutting end off of electrical plug to hardwire the spa is **NOT** recommended.

Doing so will void warranty.

Flip-open armrests with cupholder (open position)

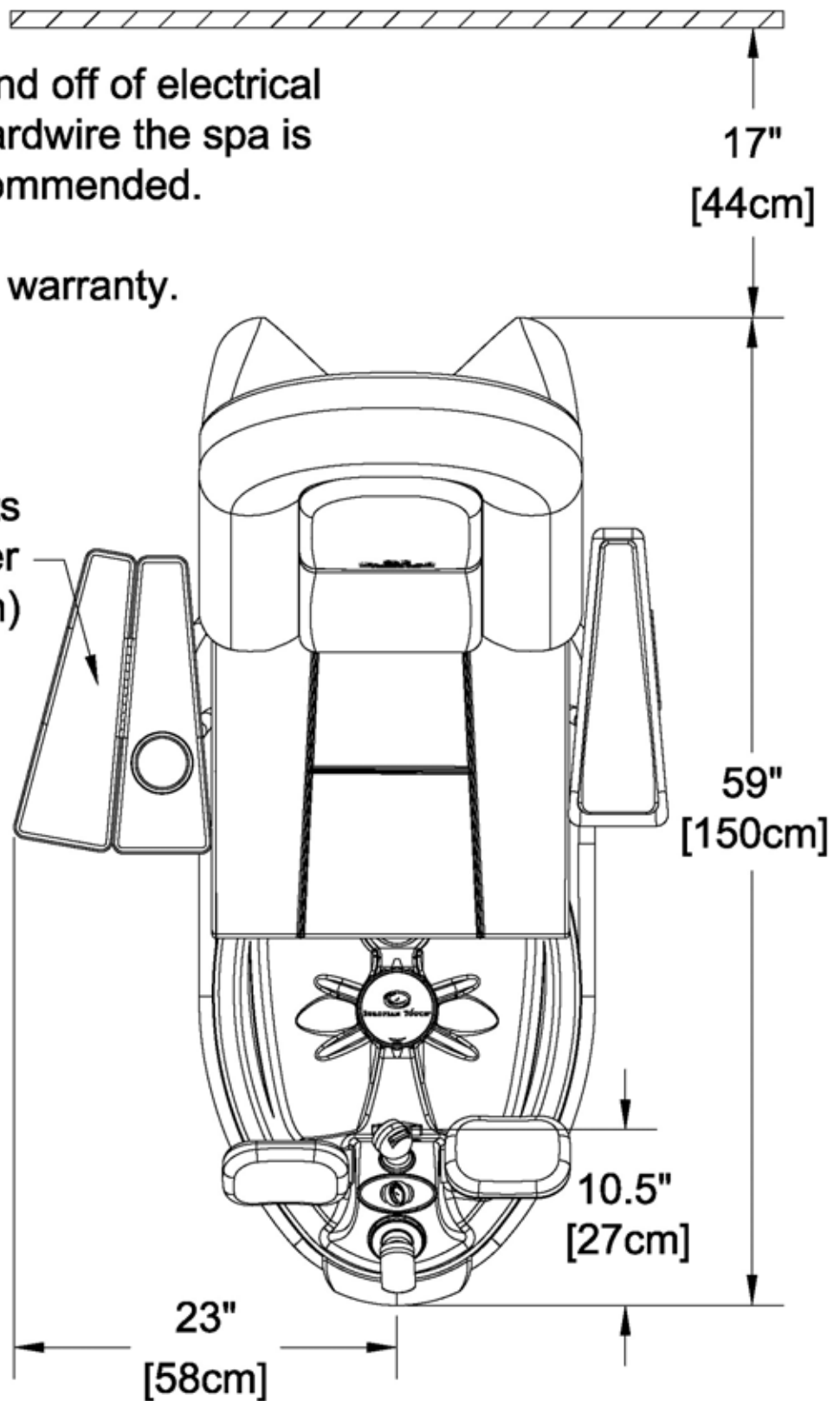

EUROPEAN TOUCH™

## Attaching the Seat Back and Seat Bottom Cushion

Make sure all parts are removed from box before discarding. If any parts are missing, contact EUROPEAN TOUCH within 30 days of delivery date for replacement at 1-800-626-6912.

This pedicure spa shipped with the seat back attached and with the seat bottom cushion in the spa shipping box. Follow these instructions to connect the seat back and the seat bottom to the pedicure spa:

**Note:** 2 people are required to perform the following instructions.

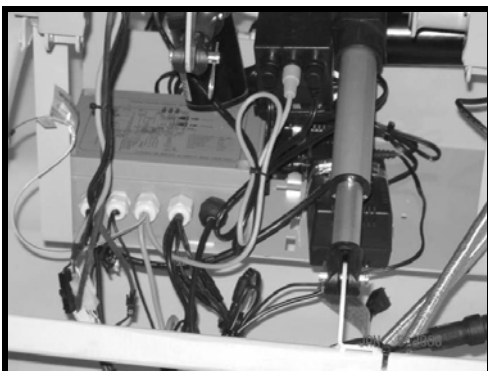
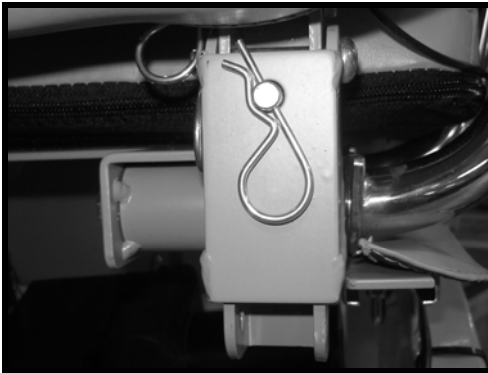
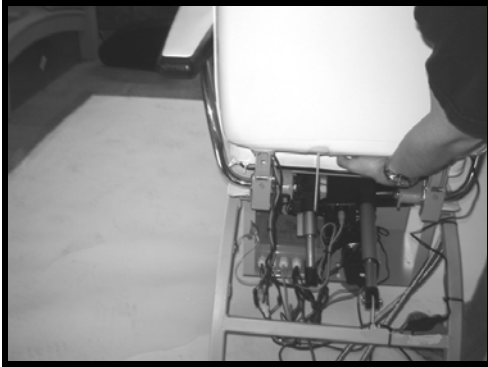

### Seat Back Attachment

1. Lift seat back vertically and lower into position.
2. Align seat back bracket holes and insert clevis pin from front.
3. Push hitch pin into the clevis pin as shown.

*Note:* Repeat steps 2 and 3 for other side.



*Clevis Pin    Hitch Pin*

### Seat Movement Attachment

4. Remove the linear drive hitch and clevis pins located on the seat back mounting bracket on the back of the chair.
5. Slide the seat bracket, insert attached, into the black end on the linear actuator and line up the holes. Slide the clevis pin through the holes and secure by inserting the hitch pin through the small hole on the clevis pin.



### Seat Bottom Attachment

1. Remove the seat bottom cushion from top of spa basin.
2. With the chair fully reclined, attach the seat bottom cushion to the spa by aligning the cushion with Velcro strips. Ensure that rear of seat bottom cushion is tight against the seat back.
3. Move seat forward and attach bottom cushion heat wire connectors as shown.

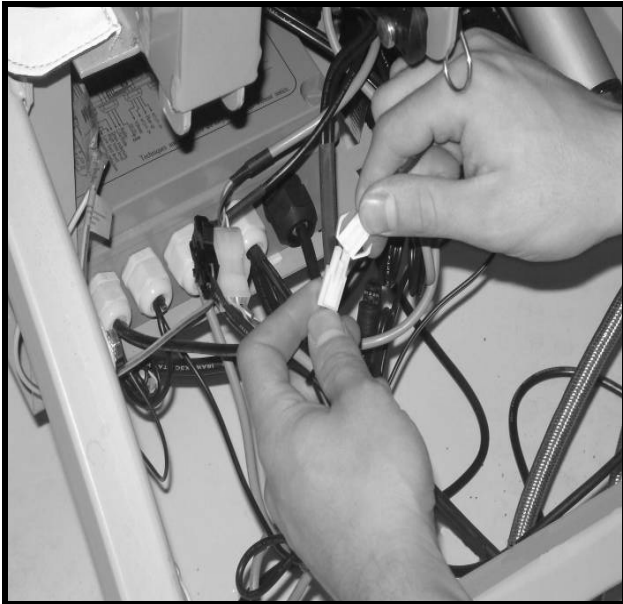

# Installing and Removing the Panel

To install the shells on your spa follow the instructions below:



Steps 1 & 2



Step 3

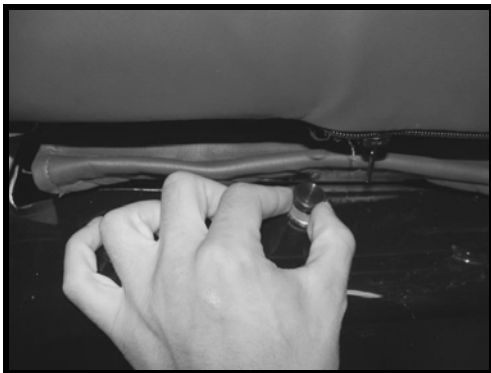

Step 4

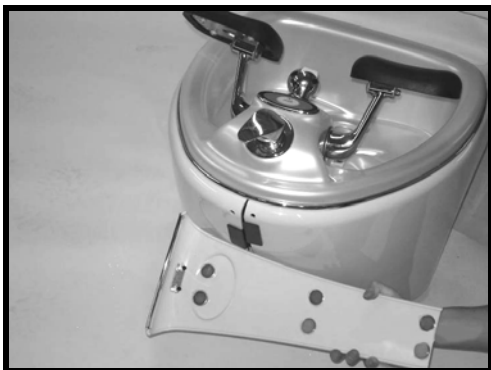

Step 5

1. Align the magnets on the frame legs with matching brackets found on the inside of the side panel. There is one set on each leg.
2. Slightly lift side panel into place on spa frame.
3. The side panel should fit under lip of basin as shown.



4. Align the thumbscrew holes located under cushion skirt and install thumbscrew on each side.
5. Install the front plate by aligning pegs to matching holes and pressing into place.



EUROPEAN TOUCH™

## Installing the floor Mounting Brackets

All Rinato Spas installed with gravity drain and / or hard piped to hot and cold supply lines **MUST** be anchored to the floor.

**Note:** Moving spa with flexible hose connected may cause strain and cause leaks.

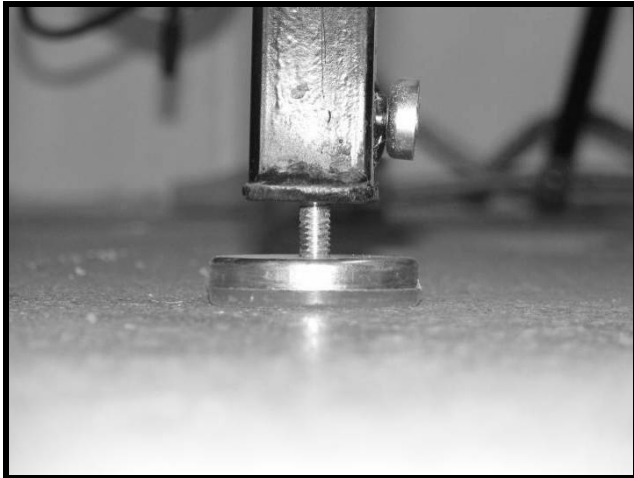

1. Adjust all 4 leveling feet until unit is stable and level.

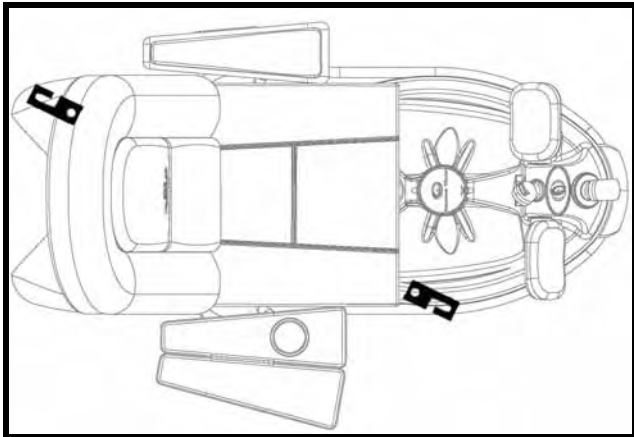

2. Place the floor mounting brackets on one of the front feet and on the rear foot of the opposite side.

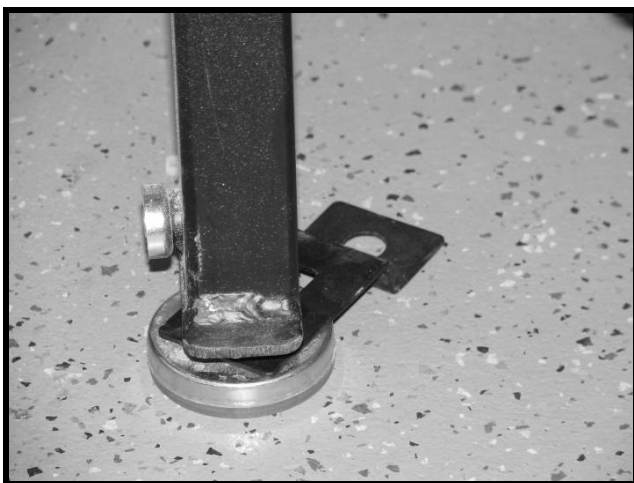

3. Mark and drill hole in floor for each bracket and install 3/8" floor anchor in each hole.



EUROPEAN TOUCH™



EUROPEAN TOUCH™

## GROUNDING INSTRUCTIONS

This product must be grounded. If it should malfunction or break down, grounding provides a path of least resistance for electric current to reduce the risk of electric shock. This product is equipped with a cord having an equipment-grounding conductor and a grounding plug. The plug must be plugged into an appropriate outlet that is properly installed and grounded in accordance with all local codes and ordinances.

### **DANGER**

Improper connection of the equipment-grounding conductor can result in a risk of electric shock. Check with a qualified electrician or serviceman if you are in doubt as to whether the product is properly grounded. Do not modify the plug provided with the product – if it will not fit the outlet, have a proper outlet installed by a qualified electrician.

This product is for use on a nominal 120-V circuit and has a grounding plug that looks like the plug illustrated in the sketch below. Make sure that the product is connected to an outlet having the same configuration as the plug. No adapter should be used with this product

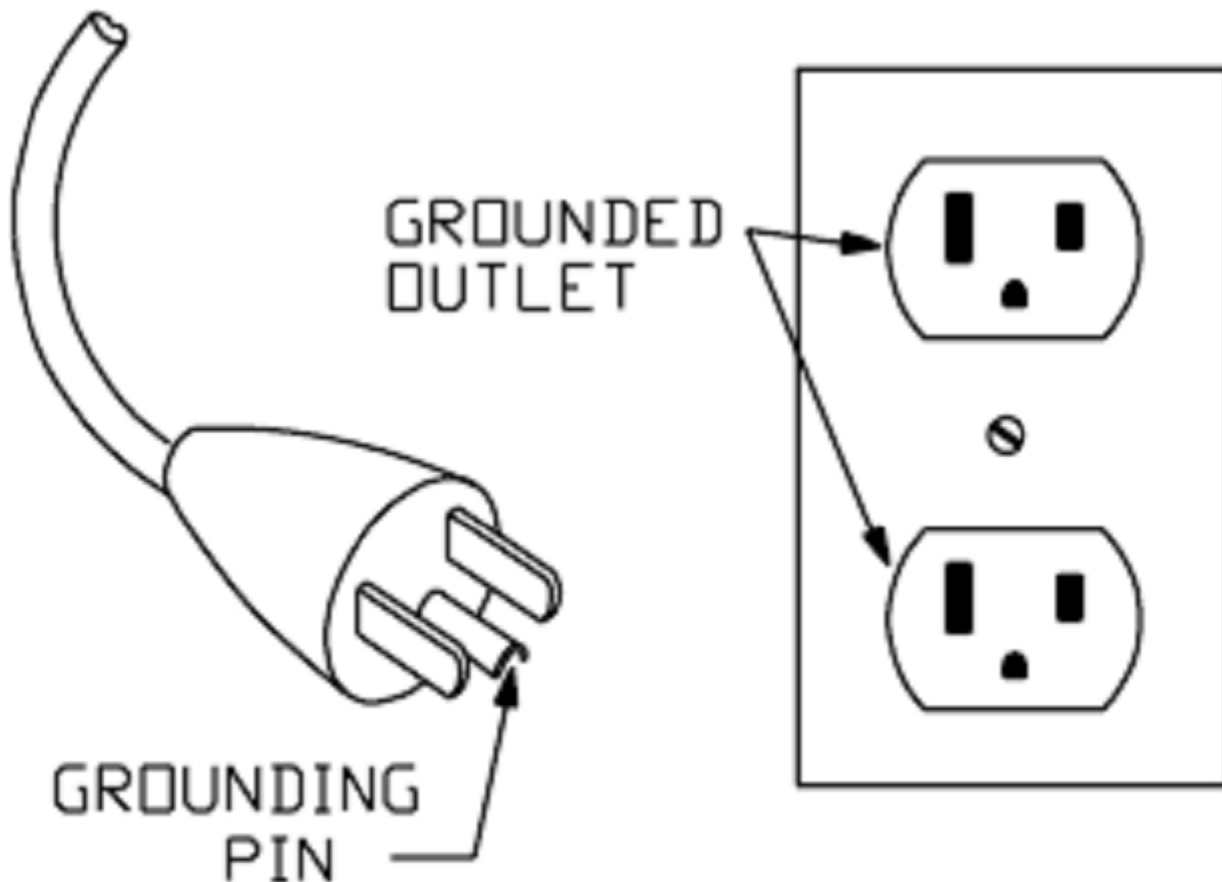



# EUROPEAN TOUCH™

**EUROPEAN TOUCH  
8301 W. Parkland Court  
Milwaukee, WI 53223**

**Phone Number: 414-357-7016  
Toll Free: 800-626-6912  
Fax: 414-357-6360**

**Web Site: [www.europeantouch.com](http://www.europeantouch.com)  
Email: [info@europeantouch.com](mailto:info@europeantouch.com)**